

# House of Worship

Loudspeaker System  
Design Reference Guide



**BRINGING  
VENUES  
TO LIFE™**



***Houses of worship come in many sizes, styles and configurations, ranging from traditional to contemporary, with many in between. This Design Guide offers coverage options and suggestions for some common types of worship spaces.***

***Community strives to assist you in providing the best sounding worship experience. For additional information, please refer to our website and/or contact our TAG Team (Technical Applications Group).***



# Contents

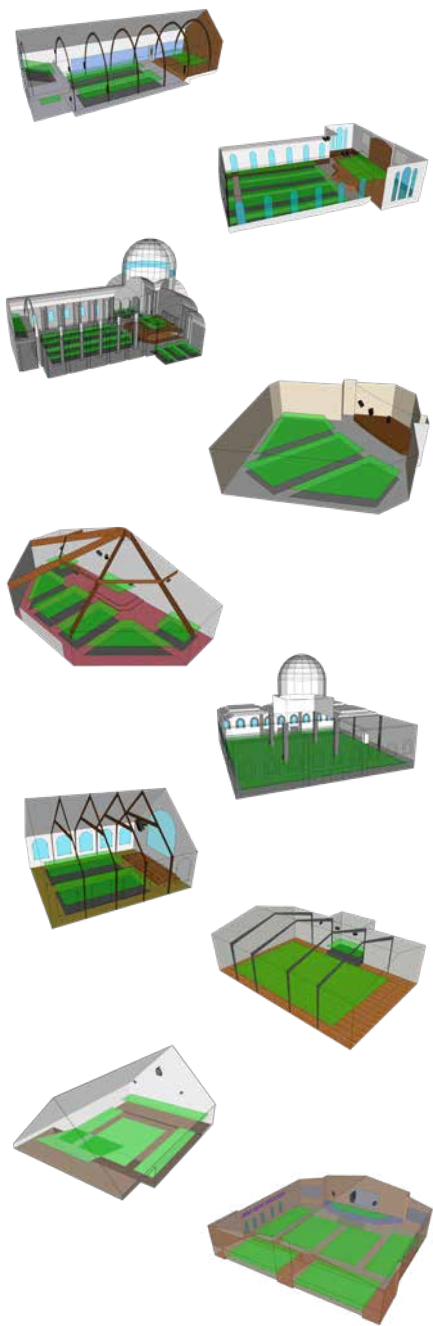

**Traditional**  
 'Tall and Narrow' ..... Page 4

**Modern**  
 'Wide Nave, Medium Height Ceiling' ..... Page 5

**Traditional Cruciform**  
 'Long Nave with Side and Balcony Seating' ..... Page 6

**Contemporary**  
 'Fan or Diamond-Shaped Coverage' ..... Page 7

**Central Podium**  
 'Half-Round' ..... Page 8

**Mosque / Open Worship Center**  
 'Reverberant Clear Space' ..... Page 9

**Local Community Church**  
 'Simple Sanctuary' ..... Page 10

**Multipurpose Social Hall**  
 'Wide Flat Space' ..... Page 11

**Mid-sized Traditional**  
 'High or Vaulted Ceiling' ..... Page 12

**Wide Contemporary**  
 'Wide Rectangular Space' ..... Page 13

**Designer Tips & Tricks**  
 'Projection and Coverage Patterns' ..... Page 14

**I SERIES**  
 'BalancePoint™ Flyware' ..... Page 15  
 'Modular Vertical Array' Accessories ..... Page 16

**Technical Considerations**  
 'Amplified Loudspeaker Controllers' ..... Page 17

**Loudspeaker Specifications** ..... Page 18

*Inside This Guide*

Image Key: Green Planes/Lines: the congregation / listener level  
 Pink Lines: the mid-line (on-axis) coverage of each loudspeaker (on Side and Top views)

# Traditional

'Tall and Narrow'

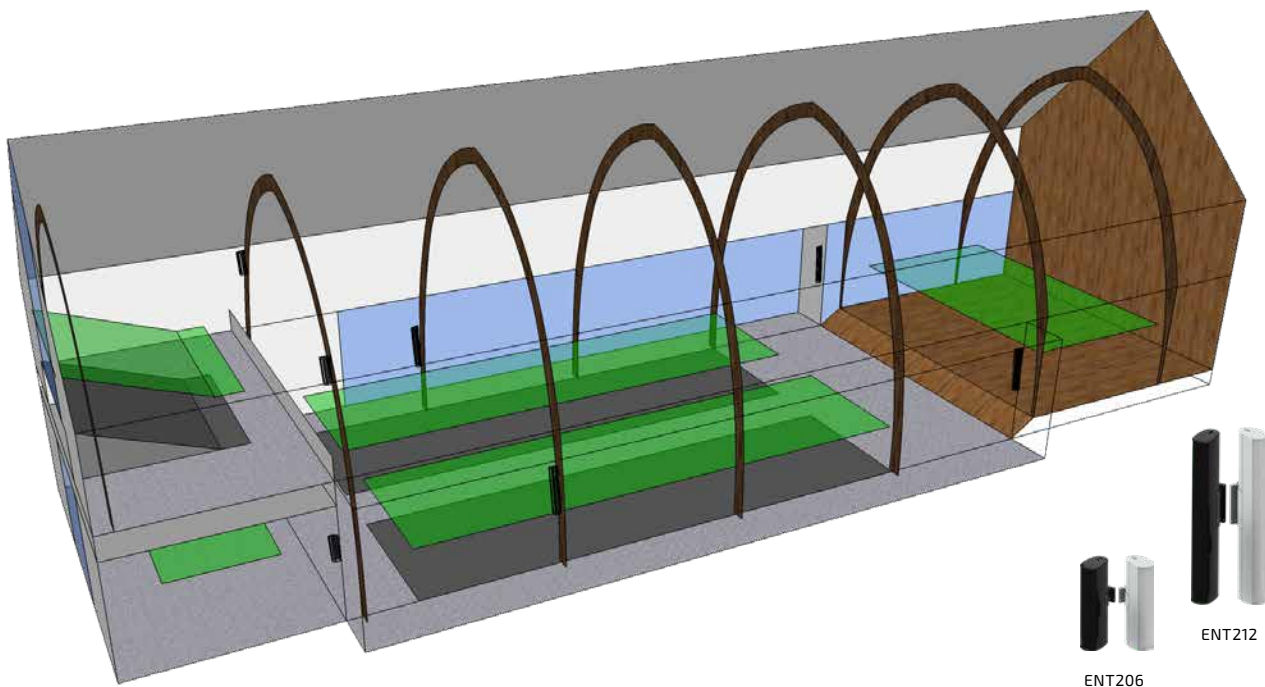

Side

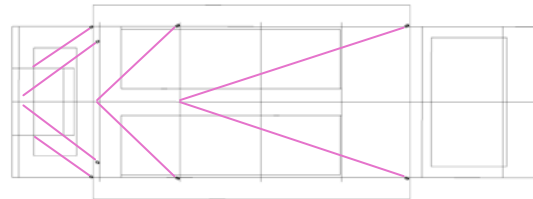

Top

## Installation Description:

Long narrow congregation area with tall sloping ceilings, full-width chancel space and extended two-level rear seating.

## Coverage Notes:

Though hard interior surfaces and high ceiling heights can enhance choir and instrumental music, the same soaring space can also degrade speech and blur faster tempo music. Highly directional loudspeakers can improve music and speech clarity by limiting the vertical dispersion (and reverberation).

We suggest using distributed column-format E SERIES loudspeakers to focus the sound on the congregational areas. Use of signal delays will allow the listeners to perceive the sound as coming from the platform areas. This example also shows rear balcony seating, but extended seating could also be on the side or as flanking balconies. Smaller column or other directional loudspeakers can cover those areas.

**Learn More:** Refer to the ENTASYS 200 Application Guide for more detail on how to specify and configure E SERIES products for similar venues.

\* Recommended Amplified Loudspeaker Controller - minimum recommended for low impedance operation with channels maximized.

## Models:

### Four (4) ENT212 (Main seating)

Two forward of the platform covering the front half and two in the middle covering the rear half

### Four (4) ENT206 (Extended and upper balcony coverage)

Two up addressing the balcony seating and two down focused on the center of the rear extended congregational area

### One (1) ALC-404D\*

*For increased fidelity, single ENT-FR modules can substitute for each of the ENT212 column loudspeakers mentioned above. This will also require a change to an ALC-1604D\*.*

# Modern

'Wide Nave, Medium Height Ceiling'



IC6-1082  
(Compact fill)



(2) IP6-1122, (1) IS6-212  
with VSB-SBR54

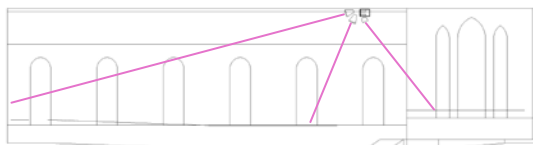
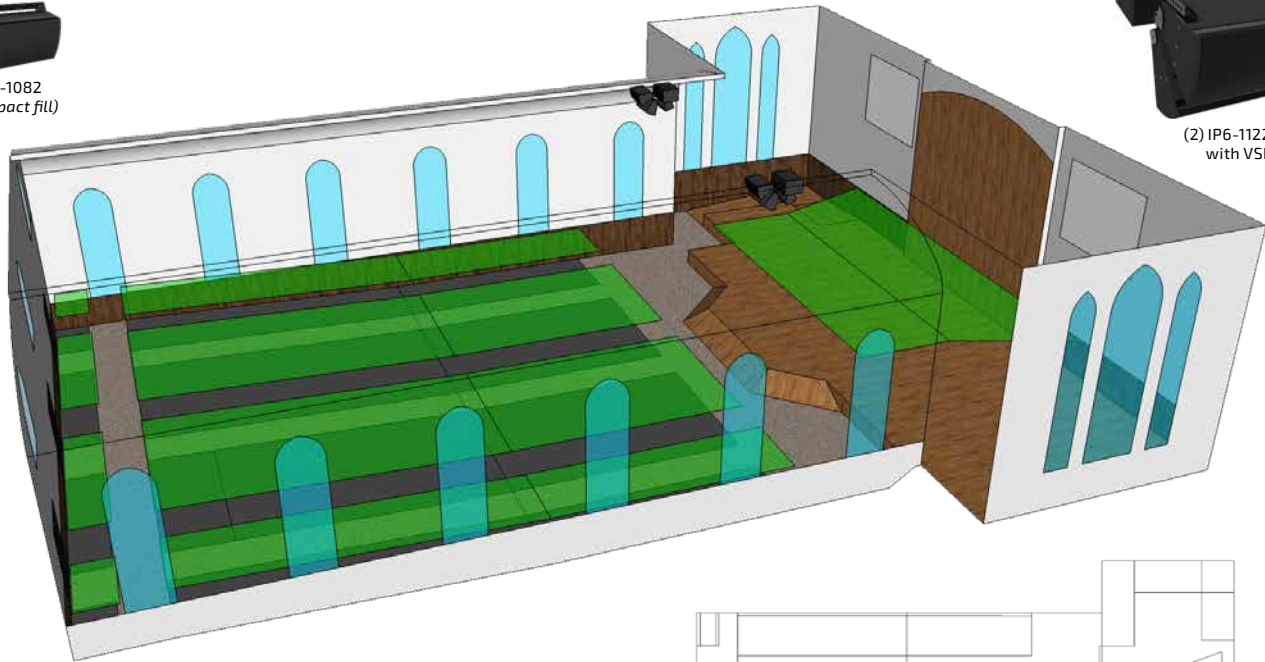

Side

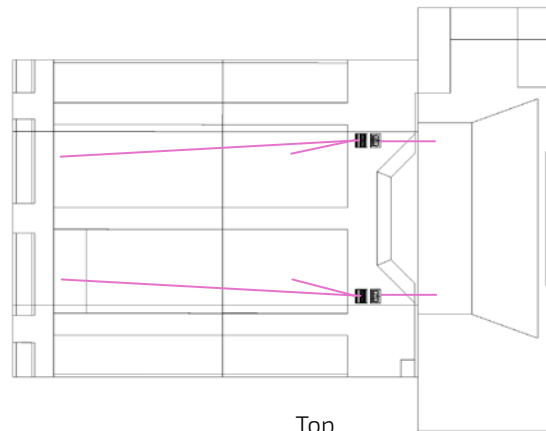

Top

## Installation Description:

Broad front chancel / podium space and a moderately wide and deep congregation area. Loudspeaker mounting is somewhat limited by a medium ceiling height.

## Coverage Notes:

In this example, we have used two matching arrays. Each loudspeaker cluster addresses one-half of the audio system and includes two horizontally oriented (landscape) cabinets with rotated horns<sup>1</sup>. In each array, the upper loudspeaker is aimed to project to rear seats using narrow vertical dispersion angle (in this case 90° H x 40° V). The lower loudspeaker is aimed downward addressing closest seats with a wider vertical dispersion (in this case 120° H x 60° V). Refer to the Side View coverage lines (pink).

In some cases, particularly more narrow rooms, each array can be located farther "off-stage" for truer Left / Right "Stereo" coverage. Each array must address all seats to achieve the desired effect.

<sup>1</sup>Horns are rotated 90° from factory standard configuration to maintain the coverage pattern.  
Suggested model families: I SERIES (IP600, IP800, IC600) and V SERIES (V2-6, V2-26, V2-8, V2-28, V2-32, V2-35)

**Amplified Loudspeaker Controllers:** One (1) ALC-1604D\* and One (1) ALC-404D\*

\* Recommended Amplified Loudspeaker Controllers - minimum recommended for low impedance operation with channels maximized (includes subwoofers and fill speakers).

## Subwoofers:

This system shows I SERIES subs positioned behind the main array to offer a tight bass response to the listeners. Coupled floor mounted subs are preferred in most situations for additional low frequency support, but in this case, distributed floor positioned subs would be too close.

## Fill Speakers:

For general monitoring purposes a compact loudspeaker mounted below each subwoofer aims toward the front platform. Portable monitors (MX8, MX10) can be an option for individual stage performers.

# Traditional Cruciform

'Long Nave with Side and Balcony Seating'

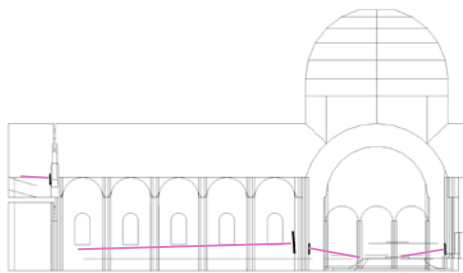
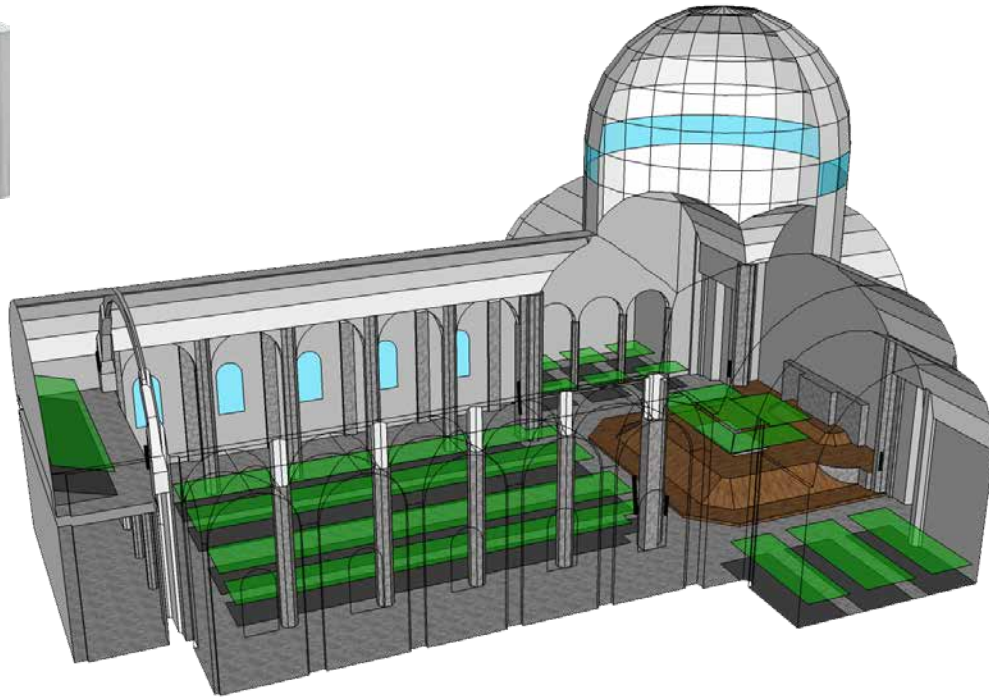

Side

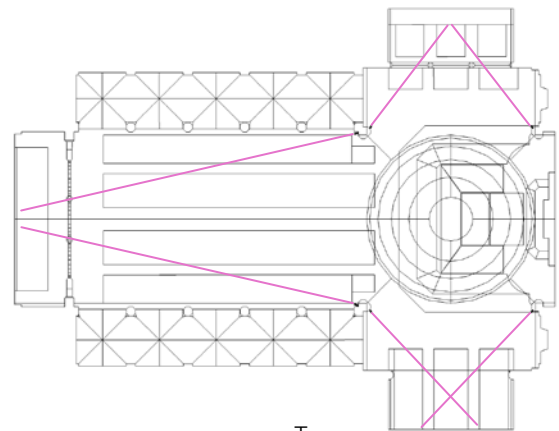

Top

## Installation Description:

Large traditional church with a long nave and auxiliary seating in the transept and balcony areas. The system should not detract from the architectural details, but needs to provide intelligible speech and clear music.

## Coverage Notes:

To ensure clear speech delivery, ENTASYS ENT-FR line array column loudspeakers strategically surround the altar area to direct sound to the intended listeners. These highly directional loudspeakers minimize reverberation and microphone interference.

As a modular system, the ENT-FR modules can be stacked vertically to offer greater directivity over longer distances. Single ENT-FR modules, or the two-way point source ENT212, can extend coverage to the transept seating from two directions to ensure all areas are covered.

Use of advanced acoustics software (i.e. EASE® Focus), and careful positioning and aiming will allow the congregation to hear amazingly natural sounding speech content. Music amplified over this system will not only project more clearly, but can be played at higher tempo because it is less subject to the long decay times.

## Auxiliary Seating:

The balcony seating falls out of the nave system coverage and requires flanking ENT212 units with applied signal delay. IC600 compact point source models mounted overhead are another option.

Transept seating is addressed by a pair of ENT-FR (or ENT212) units with applied signal delay. Smaller transept areas can be serviced by smaller ENT200 models.

## Amplified Loudspeaker Controller:

One (1) ALC-1604D\*

\* Recommended Amplified Loudspeaker Controller - minimum recommended for low impedance operation with channels maximized.

# Contemporary

## 'Fan or Diamond-Shaped Coverage'



IP6-1152 with Vertical Yoke



IP6-1122 with BalancePoint Fly Rails

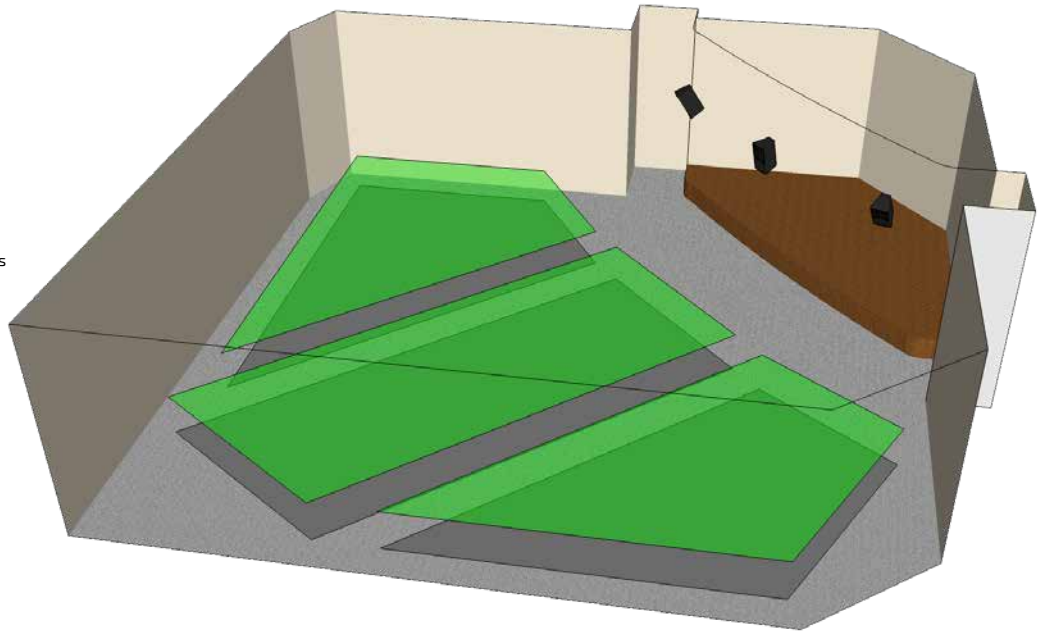

Side

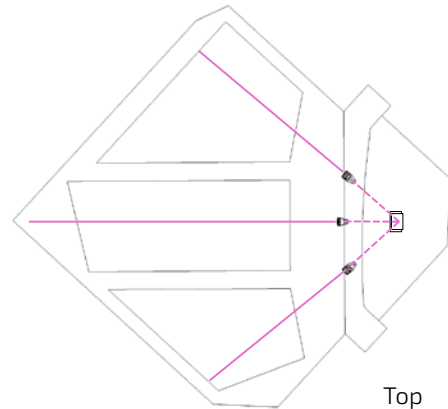

Top

### Installation Description:

Platform area located in one corner creates a diamond-shaped congregational seating area requiring wide horizontal coverage.

### Coverage Notes:

The loudspeakers align across the platform and aim along the centerline of each congregational section. In most cases, it is best to also align the loudspeaker's on-axis projection with the presenter's position (podium, pulpit, altar, etc.). This will lead to a wider loudspeaker grouping, though they all radiate from one 'virtual' central position above the platform (see dashed line on Top View). The loudspeaker horn patterns must be carefully selected to address each seating area with care to minimize overlapping effects.

In most cases, medium format two-way I SERIES models and three-way V SERIES models offer a wide range of choices to suit these requirements. In larger versions of this venue, IP8-1153 three-way loudspeakers can be used.

### Amplified Loudspeaker Controllers (per coverage option):

- (3) V SERIES 3-way - **One (1) ALC-404D\***
- (3) I SERIES 2-way - **One (1) ALC-3202D\***
- (3) I SERIES 3 way (biamp) - **One (1) ALC-1604D\***

\* Recommended Amplified Loudspeaker Controllers - minimum recommended for low impedance operation with channels maximized (without subwoofer addition).

### Subwoofers:

Subwoofers are not shown in this model but can be mounted overhead (possibly behind the full-range loudspeakers) to preserve floor space and keep LF levels low on-stage. An additional (or different model) amplifier would be needed to control the subwoofers.



IP6-1152, IS6-115 with SBR54

# Central Podium

'Half-Round'

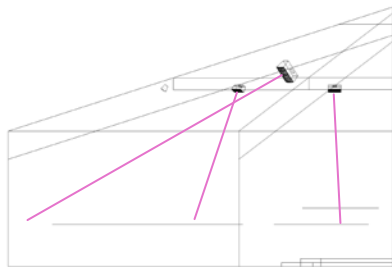
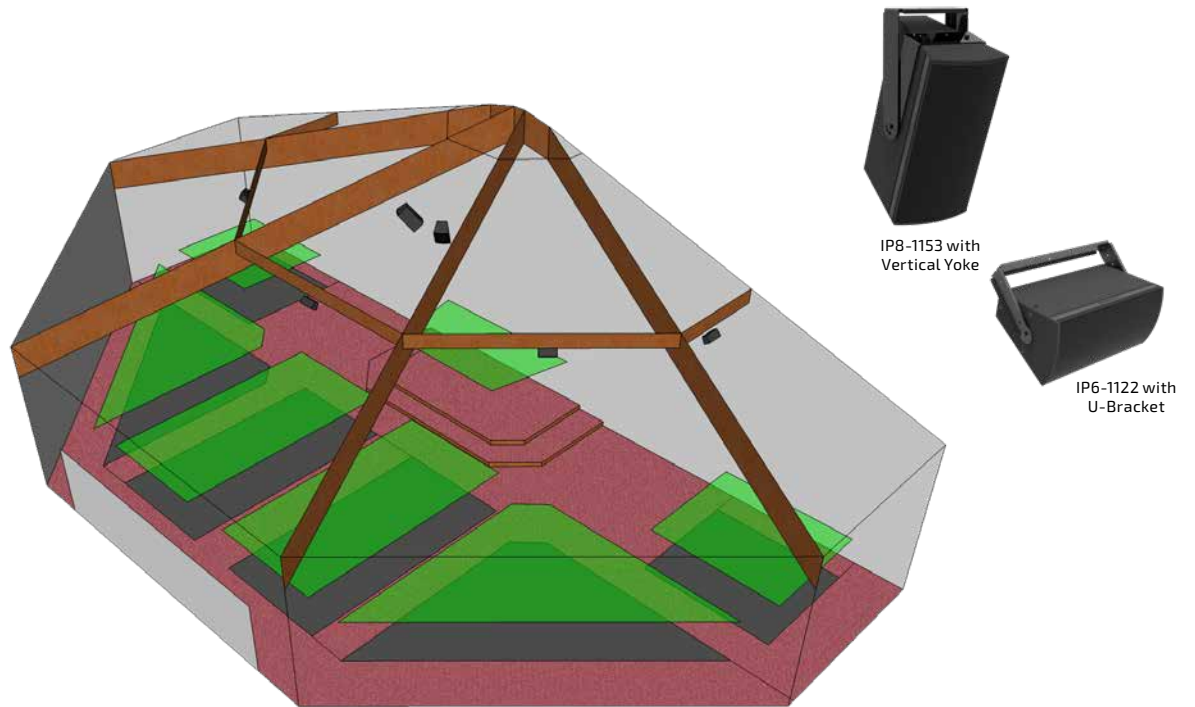

Side

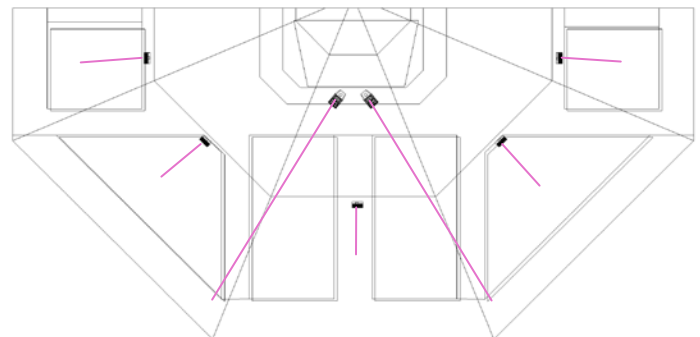

Top

## Installation Description:

In this half-round format, the congregation seating wraps around and focuses on the platform creating a more intimate environment in a larger space.

## Coverage Notes:

Align the loudspeakers with the presenter's position (podium, pulpit, stage, etc.), and address each seating area independently. Choose the appropriate coverage pattern and proper location to minimize overlapping effects in adjacent speaker zones.

In many cases, medium format two-way I SERIES models and three-way V SERIES models offer a wide range of choices to suit these requirements. In bigger versions of this venue, IP8-1153 three-way loudspeakers can be used to cover the larger seating areas. The smaller seating areas on the sides may need slightly different loudspeaker models that are similarly voiced. Subwoofers can be added to provide extra bass support.

## Amplified Loudspeaker Controllers (per coverage option):

V SERIES 3-way or I SERIES 2-way option - **One (1) ALC-1604D\***

I SERIES 3 way (biamp) system - **One (1) ALC-3202D\* and One (1) ALC-1604D\***

\* Recommended Amplified Loudspeaker Controllers - minimum recommended for low impedance operation with channels maximized (without subwoofer addition).



# Mosque / Open Worship Center

'Reverberant Clear Space'

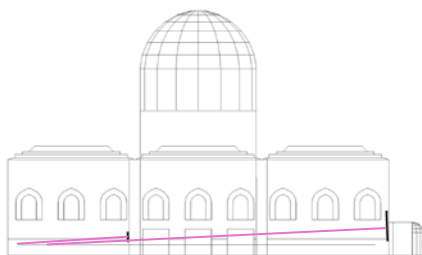
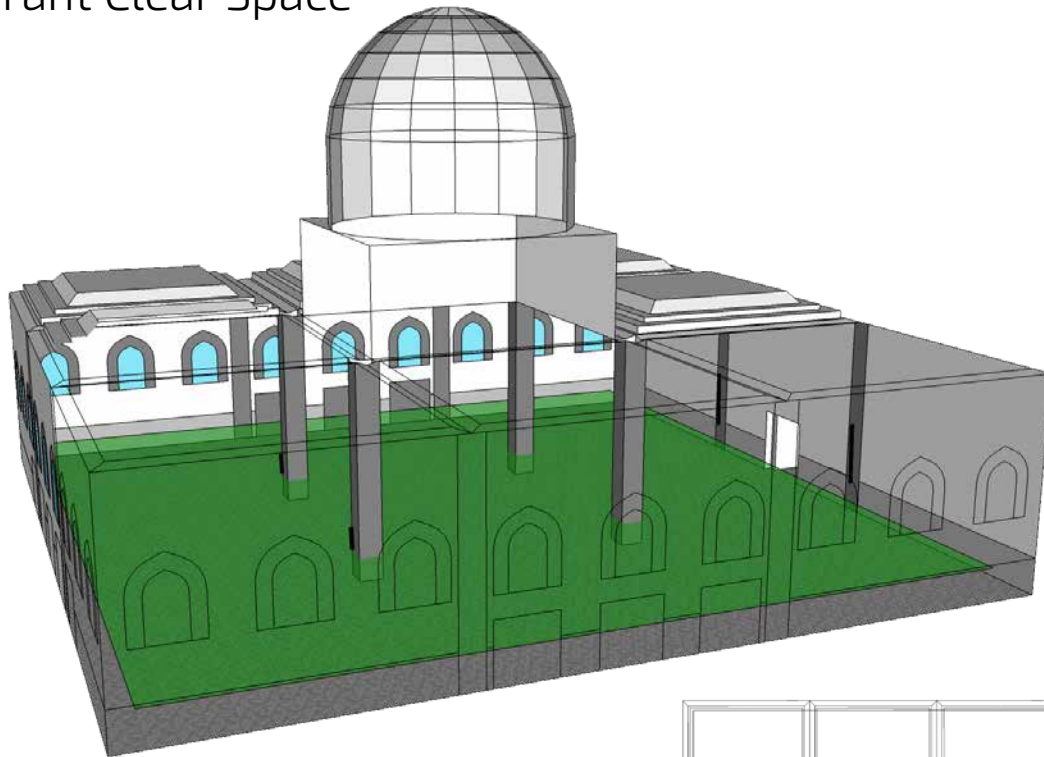

Side

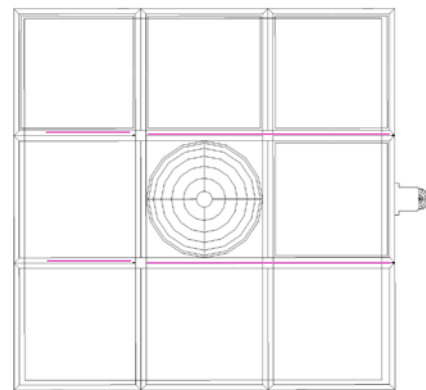

Top

## Installation Description:

This is a mostly open, large space with structural pillars or columns supporting the ceiling and vaulted spaces. A relatively unobtrusive audio system preserves the architectural themes, and minimizes sound reflections on upper walls and ceilings.

## Amplified Loudspeaker Controller

For (2) ENT-FR arrays [with 2-4 modules stacked per array]

- **One (1) ALC-1604D\***

\* Recommended Amplified Loudspeaker Controllers - minimum recommended for low impedance operation with channels maximized.

## Coverage Notes:

Delivering speech clearly to large spaces with acoustically reflective surfaces must be balanced. To accomplish clear speech delivery, position ENTASYS ENT-FR line array column loudspeakers to direct sound to the intended listeners. Stacked 2-4 module ENT-FR arrays flanking the cleric addresses the majority of listening areas and provides directionality from the presenter. Using these highly directional loudspeakers minimizes impact on the reflective surfaces and microphones.

## Additional Considerations:

Nearby listeners can benefit when rear and side wall reflections are directed back to them. This reflected sound can also be partly absorbed by the congregation (when fully occupied) reducing "slap back" effects.

In similar larger spaces, supplemental arrays may need to be taller to cover the related distance. Additional loudspeakers may also be needed on all of the interior columns to cover acoustically shadowed areas or to address the extended space. Sometimes, larger delay zones do not integrate well, and smaller zones addressed by single ENT-FR (or ENT200) models better optimize intelligibility.

# Local Community Church

'Simple Sanctuary'

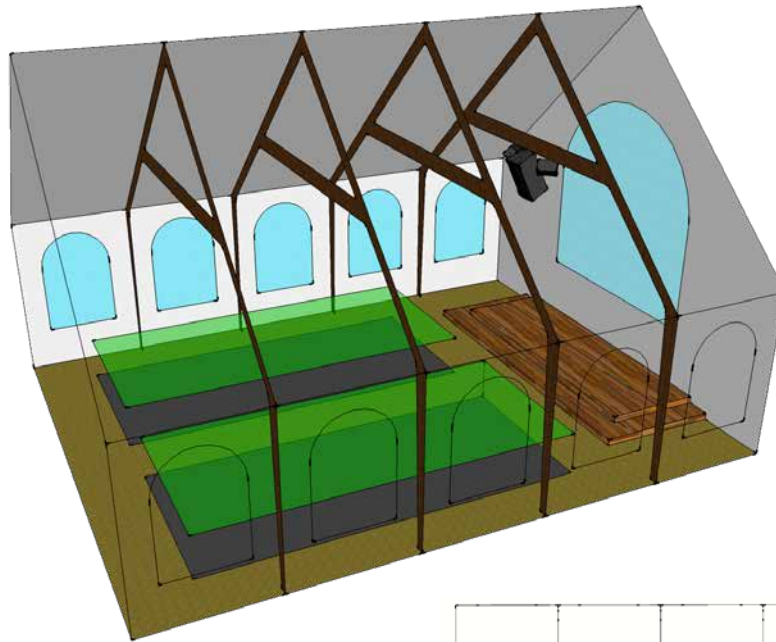

IP6-1122 with Vertical Yoke



IC6-1062 with U-Bracket

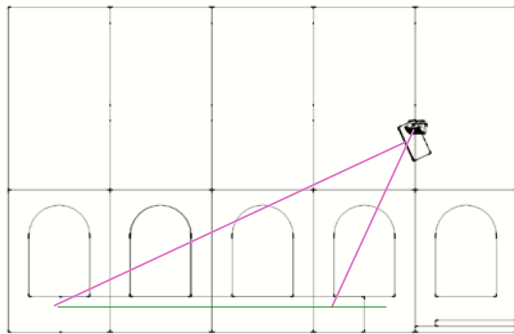

Side

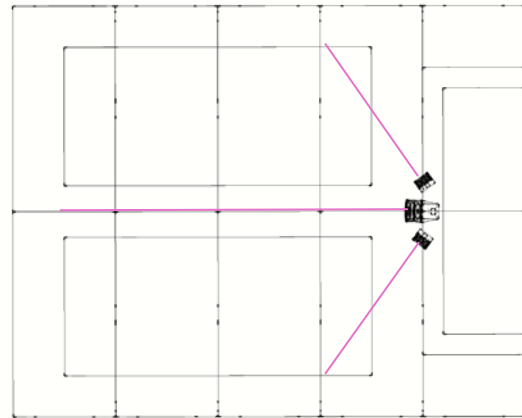

Top

## Installation Description:

Smaller local church faced with the need for a modest PA system balanced with the need to improve speech clarity for the congregation without overwhelming the architecture. The system must also often be capable of reinforcing amplified instrumentation.

## Coverage Notes:

A compact, monaural, centrally located array preserves the center focus (listening localization) on the lectern while full-range two-way or three-way loudspeakers provide sufficiently accurate reproduction of musical instruments.

A slightly more sophisticated design might supplement this with "stereo" Left / Right matching loudspeakers for reinforcement of stereo instruments. For deep bass instrumentation a subwoofer can be placed near the platform center, or close to the musicians, to add range for increased low-frequency support.

**Note:** Twin side fill compact loudspeakers require separate signal processing for delay, gain, and equalization to fully integrate with the main center loudspeaker.

## Amplified Loudspeaker Controller:

For Options A, B, & C - **One (1) ALC-404D\***

(If a IS600 subwoofer is added, use one (1) ALC-1604D\* for the full system)

## Option A:

**One (1) V2-1296 (center)**  
**Two (2) V2-8 (L/R sides)**

## Option B:

**One (1) V2-3294 (center)**  
**Two (2) V2-8 (L/R sides)**

## Option C:

**One (1) IP6-1122/96 (center)**  
**Two (2) IC6-1062 (L/R sides)**

## Subwoofer Enhancement:

**VLF208LV, V2-212S, or IS600 family (any size)**

\* Recommended Amplified Loudspeaker Controllers - minimum recommended for low impedance operation with channels maximized.

# Multipurpose Social Hall

'Wide Flat Space'

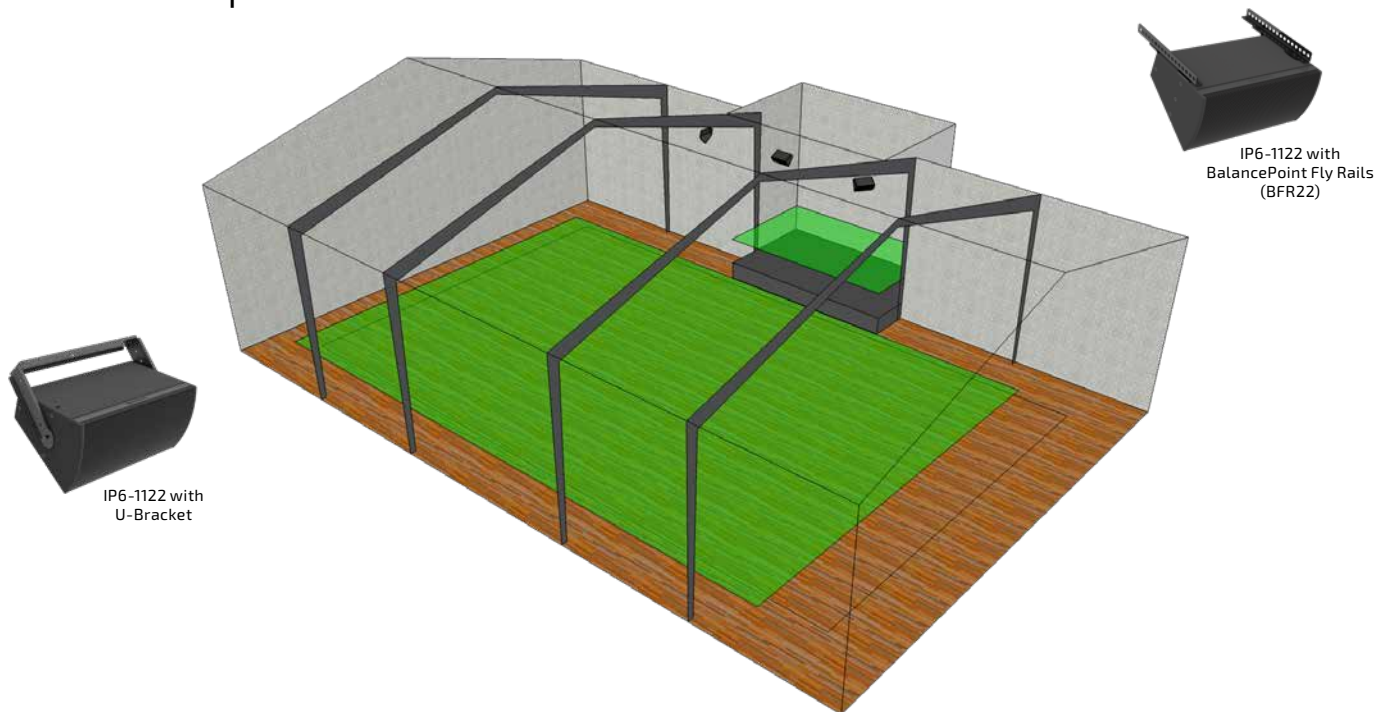

IP6-1122 with U-Bracket

IP6-1122 with BalancePoint Fly Rails (BFR22)

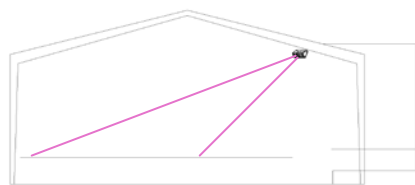

Side

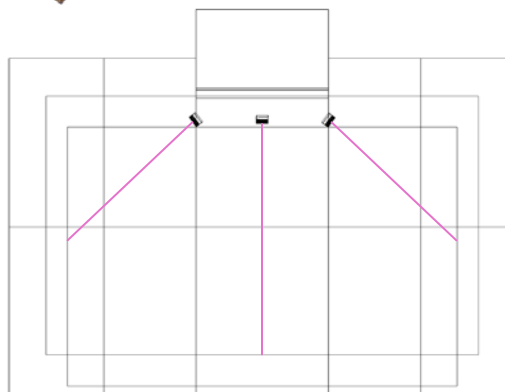

Top

## Installation Description:

This Social Hall or Community Room is a multipurpose space used for a variety of activities, functioning as a cafeteria, gym, auditorium or gathering space. It may be challenging to provide a single audio solution that addresses all of these uses and related events.

## Coverage Notes:

The Side and Top views above show an array of horizontally oriented loudspeakers<sup>1</sup> that provide coverage to the left, center and right of the space. Each loudspeaker likely needs a wider vertical dispersion and a narrower horizontal pattern to provide the best coverage. Usually, the loudspeaker's on-axis projection should be aligned with the center of the platform.

<sup>1</sup>Horns are rotated 90° from factory standard configuration to maintain the coverage pattern.

## Amplified Loudspeaker Controller:

For (3) IP6-1122 system - **One (1) ALC-1604D\***

\* Recommended Amplified Loudspeaker Controllers - minimum recommended for low impedance operation with channels maximized.

## Subwoofer (optional):

When possible, distributing subwoofers across the front of the platform offers even coverage, but mounting them overhead may be necessary to preserve floor space.

## Related Design:

Larger halls like this, with dedicated seating for sports, may benefit from a concurrent layout from the Sports Sound Loudspeaker Design Reference Guide.

# Mid-sized Traditional

'High or Vaulted Ceiling'

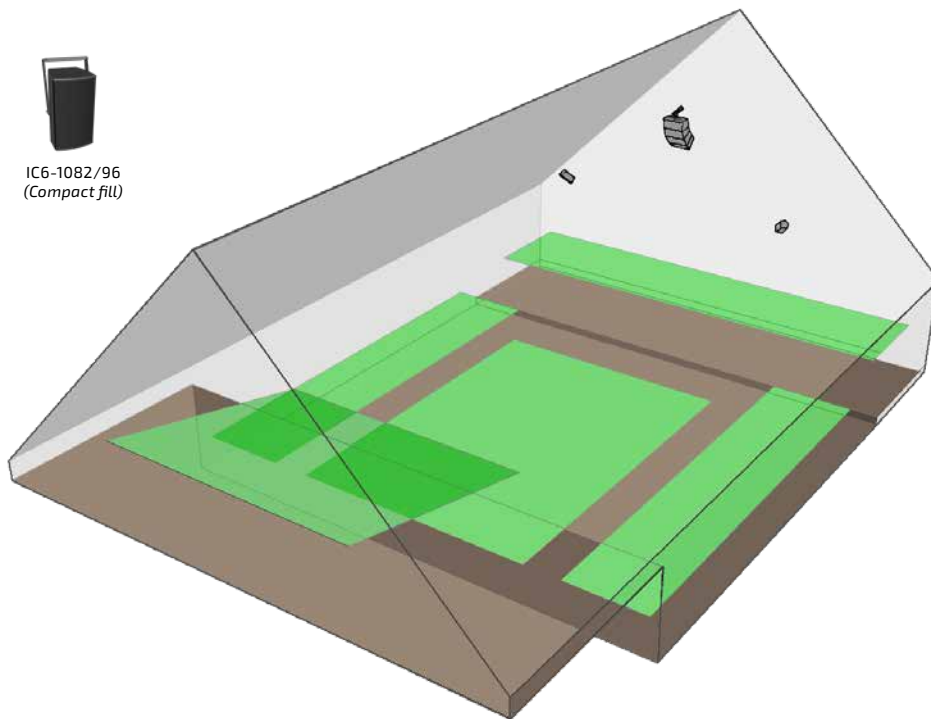

IC6-1082/96  
(Compact fill)



IV6-1122/15 (4) with  
IV6-GP-AF

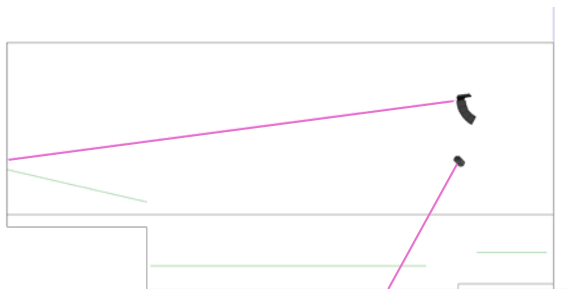

Side

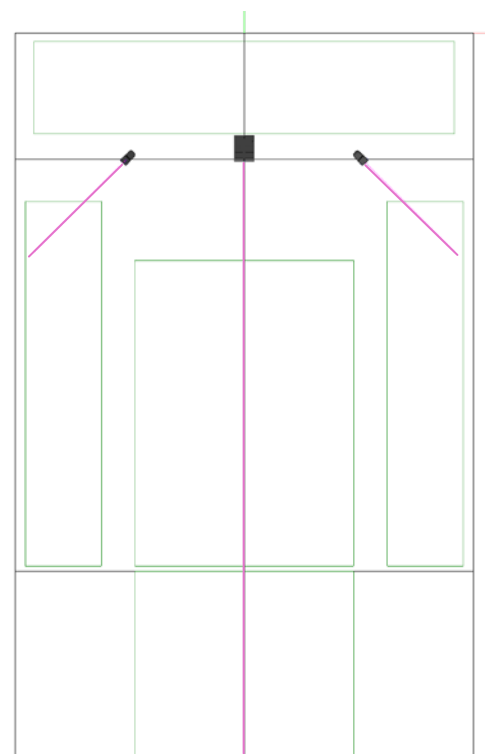

Top

## Installation Description:

Mid-size congregation area with tall sloping ceilings, full-width chancel space and raised rear seating.

## Coverage Notes:

Though hard interior surfaces and high ceiling heights can enhance choir and instrumental music, the same soaring space can also degrade speech and blur faster tempo music. The center main array is mounted high and will cover all but the most forward right and left seats. The IC6-1082's provide directed coverage to those areas. This also improves localization to help listeners in the front corners to focus their attention on the chancel area.

## Models:

**Four (4) IV6-1122/15 (Main array)**  
The main array covers most of the congregational seating area.

**Two (2) IC6-1082/96 (Front right and left fill)**

One on either side focused on the outside forward congregational areas.

**One (1) ALC-1604D\***

\* Recommended Amplified Loudspeaker Controllers - minimum recommended for low impedance operation with channels maximized.

# Wide Contemporary

'Wide Rectangular Space'

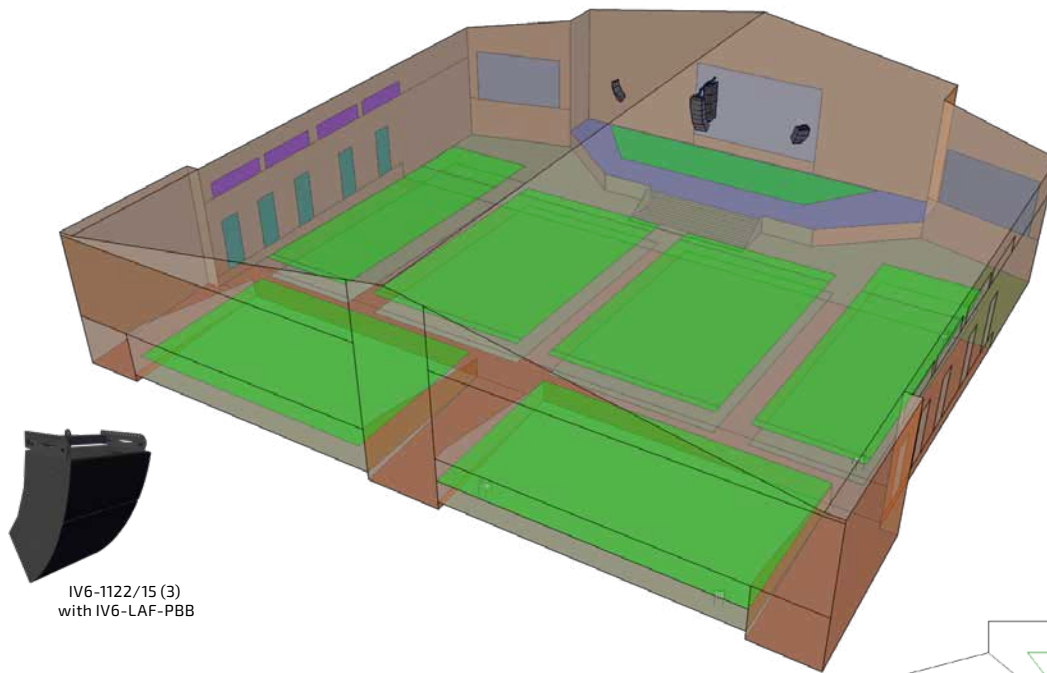

IV6-1122/15 (3)  
with IV6-LAF-PBB



IV6-1122/05 (6),  
IV6-1122/15 (1) with  
IV6-GP-AF and IV6-SB-AF

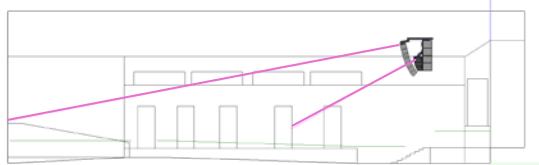

Side

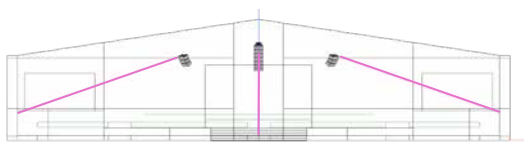

End

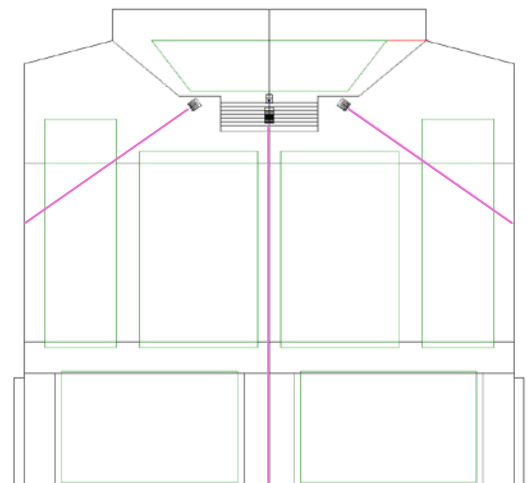

Top

## Installation Description:

This large multi-function space serves worship, conferences, and other musical events.

## Coverage Notes:

This larger space requires a larger array to focus sound over a longer distance. Equally important, the higher directivity minimizes amplified sound striking surfaces other than the audience to preserve music and speech clarity. The Side and Top views above show a main line array of (7) IV6-1122's that provide much of the coverage to the entire space. Two smaller curved arrays of (3) IV6-1122/15's cover the forward left and right audience spaces. Subwoofers are shown flown vertically stacked behind the main array to deliver coherent bass summation and extension. The elevated position consumes less floor space and bass covers more evenly. They can also be distributed evenly along the perimeter of the platform.

\* Recommended Amplified Loudspeaker Controllers - minimum recommended for low impedance operation with channels maximized.

## Models:

**Six (6) IV6-1122/05 and  
One IV6-1122/15 (Main array)**

The main array covers the center, rear and part of the side seating.

**Three (3) IV6-1122/15 (x Two)  
(Symmetrical right and left forward  
audience coverage)**

One tightly curved array on either side focused on the outside forward congregational areas.

**Four (4) IV6-1185 (Deep bass)**

Vertically flown behind the main array.

**One (1) ALC-1604D\* (IV6-1122s) and  
One (1) ALC-3202D\* (subwoofers)**

# Designer Tips & Tricks

## 'Projection and Coverage Patterns'

### What is the effective projection distance for a point source loudspeaker?

Use the 3:1 rule for D2 (Distance to furthest listener) and D1 (Distance to closest listener) to approximate the area over which the loudspeaker provides +/-3dB variation in SPL:  $D2 \leq D1 \times 3$ .

### Which vertical horn pattern do I choose when there are so many options? See Figure 1.

- Determine the axial aim point to the rear seating.
  - Depending on how much the wall surfaces behind the rear seats present a "slap back" echo, defines how sharp the downward aiming angle should be.
  - For lower trim heights where the loudspeaker must project the full depth of the space, aim for the furthest listeners almost exclusively. Front seats will benefit by close proximity.
  - For higher trim heights or distributed arrays, the aim point will likely be toward the rear third or rear half of the seating.
- Choose the Nominal Vertical Coverage Angle based on the aiming axis chosen in Step 1 that will include the front seating with priority over the rear seats.
- If the vertical angle becomes too tall and will project too much on the ceiling or other non-occupied areas, then consider a shorter vertical coverage angle and supplement the front seating areas with fill speakers:
  - Fill speakers can be mounted along the leading edge of the platform to address the first couple rows (i.e. Compact V SERIES or I SERIES models). This will also help those listeners better localize the direct sound to the platform.
  - Otherwise, consider a "down fill" position under the main loudspeakers with a wider angle, lower directivity product.

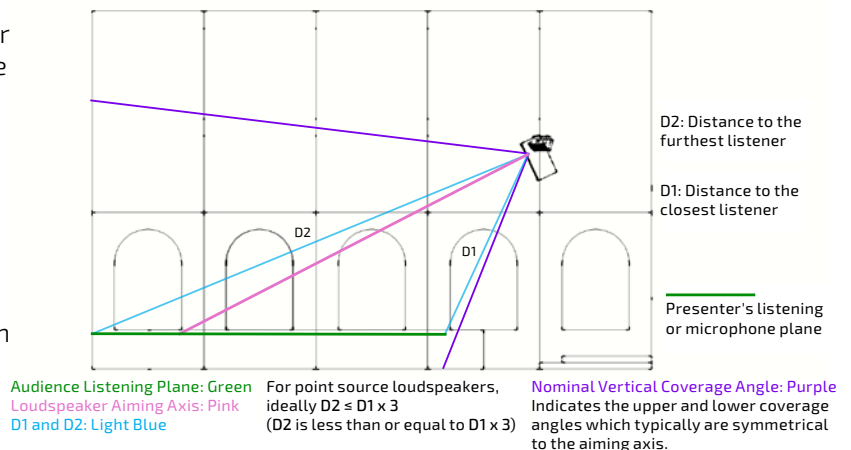

Figure 1. Determine the vertical horn pattern

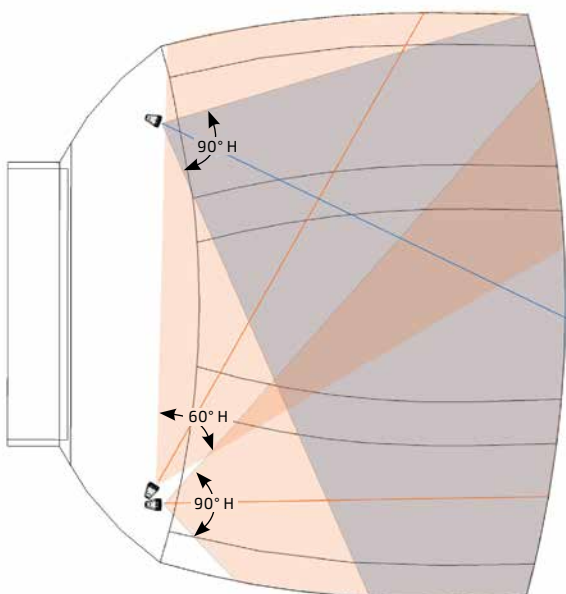

Figure 2. Coverage of single vs dual loudspeakers per side

### How do I choose the horizontal horn pattern?

Measure the angle from the furthest listener right to left (from an individual loudspeaker or group of loudspeakers).

Choose a single horn pattern for an individual loudspeaker equal to that angle.

When the coverage need is wider than a single loudspeaker can address, divide the coverage between two loudspeakers and allow 5 to 10 degrees to accommodate the overlap.

Keep in mind that the 3:1 rule also applies in the horizontal plane, and there is a limit to how far a single loudspeaker can project along the breadth of the seating.

Also, the loudspeakers aimed toward the front/center seating can be level adjusted to "amplitude shade" the coverage and maintain proper SPL uniformity.

**Figure 2:** The dual coverage (light orange) offers a more complete coverage of the full seating area. The single loudspeaker (grey) misses the outside front and front middle of the congregational seating.

# I SERIES

## 'BalancePoint™ Flyware'

Refer to the I SERIES BalancePoint™ Flyware Accessory Guide for an inclusive installation guide for all of the kits. Clicking on each of the [blue](#) model numbers will bring up the individual kit assembly instructions.

### BalancePoint™ Fly Rails

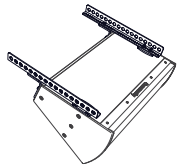

**BFR22H:** BalancePoint™ Horizontal Fly Rails  
- fly a single enclosure (landscape orientation)

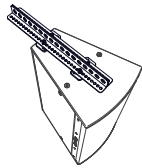

**BFR22V:** BalancePoint™ Vertical Fly Rails  
- fly a single enclosure (portrait orientation)



**SBR54:** Subwoofer behind BalancePoint™ Fly Rails (54")  
- adds one or two subwoofers behind any array configuration

### U-Brackets and Vertical Yokes

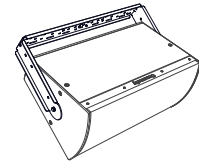

**IUB1122, IUB1152, IUB1153:** U-Brackets  
- mount and aim single full-range loudspeakers  
**IUB1122WRG, IUB1152WRG, IUB1153WRG, IUB0002WRG, IUB1125WRG:** Stainless steel U-Brackets for weather-resistant versions of loudspeakers and subwoofers

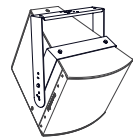
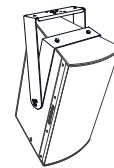

**IVY1122, IVY1152, IVY1153, IVY0002:** Vertical yokes - vertically mount and aim single full-range loudspeakers (model specific)

### Horizontal Array Kits

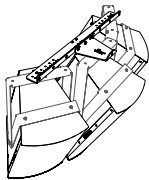

**IAF40 (2-way), IAF55 (3-way):** Isometric Array Frames  
- for two to three loudspeakers in portrait or landscape orientation (Requires U-Brackets or Vertical yokes)

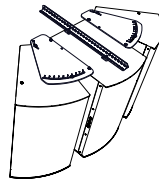

**HAB-BFR38 (2-way), HAB3-BFR38 (3-way):** Horizontal Array Brackets with BalancePoint™ Fly Rails Kit - to array two full-range cabinets with a subwoofer in between

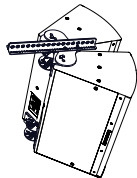

**HSB-BFR22 (2-way), HSB3-BFR22 (3-way):** Dual Horizontal Splay Kits  
- horizontally array two full-range models

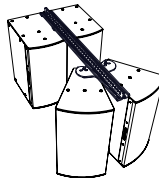

**HSB-SBR54 (2-way), HSB3-SBR54 (3-way):** Horizontal Splay Brackets with BalancePoint™ Fly Rails Kit - to array two full-range loudspeakers with subwoofer(s) behind

### Array Accessory Kits

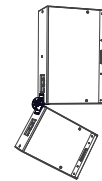

**DFS:** Downfill Splay Bracket - to add a downfill loudspeaker to any array



**HVS (2-way), HVS3 (3-way):** Horizontal/Vertical Splay Brackets - to add one additional loudspeaker to an array

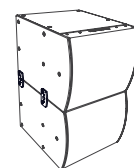

**TPK:** Tight Pack Kit - to connect any pair of loudspeakers or subwoofers that share common suspension points

### Vertical Array Kits

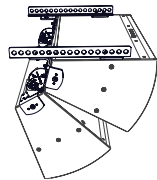

**VSB-BFR22 (2-way), VSB3-BFR22 (3-way):** Vertical Splay Kits - to vertically array two full-range models

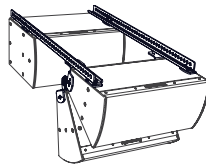

**VSB-SBR54 (2-way), VSB3-SBR54 (3-way):** Vertical Splay Brackets with BalancePoint™ Fly Rails - to array two full-range loudspeakers with subwoofer behind

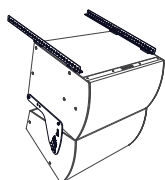

**VAB-BFR38:** Vertical Array Brackets with BalancePoint™ Fly Rails Kit  
- mount and aim a full-range cabinet under a subwoofer

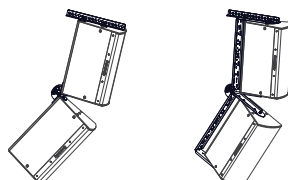

**DVS-BFR22:** Dual Vertical Splay with BalancePoint™ Fly Rails - to vertically array and aim two loudspeakers or loudspeaker/subwoofer combination (Can also be used with one or two U-Brackets)

# I SERIES

## 'Modular Vertical Array' Accessories

Refer to the I SERIES Modular Vertical Array Accessory Guide for a comprehensive installation guide and additional information about each accessory.

### Splay Brackets

Splay brackets are required to connect the elements in the array. One pair must be ordered for each cabinet-to-cabinet connection.



IV6-S1  
Pair



IV6-S2  
Pair



IV6-S3  
Pair

### Accessories - optional



PY1-EN750-1550  
Lift Point for Array  
Frames

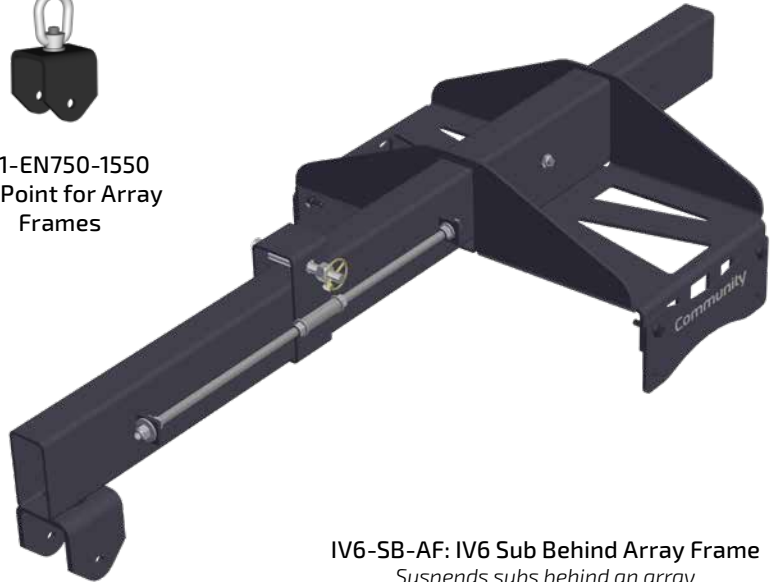

IV6-SB-AF: IV6 Sub Behind Array Frame  
*Suspends subs behind an array*

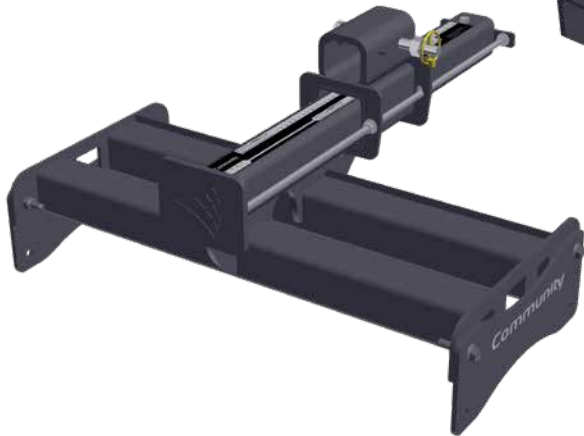

IV6-GP-AF: IV6 Glidepoint™ Array Frame



IV6-GP-AF and IV6-SB-AF



IV6-LAF-PBB: IV6 Light Array Frame/Pullback Bar  
*Can support up to six IV6-1122s, or can be used at the bottom of a longer array as a pull back bar*



IV6-LAU: IV6 Light Frame Adapter U-Bracket  
*Shown individually (at left) and in its normal use (right) attached to the IV6-LAF-PBB for under-balcony applications*

Additional mounting and rigging accessories are available from Polar Focus ([www.linearrayframes.com](http://www.linearrayframes.com))



# Technical Considerations

## 'Amplified Loudspeaker Controllers'



Community recommends our series of Amplified Loudspeaker Controllers (ALC) for all Community loudspeaker applications, like those shown in this application guide. ALCs provide all of the signal routing, zone switching, DSP processing, protective limiting, remote monitoring, and amplification functions needed between a mixer and the loudspeakers in virtually any Community Professional Loudspeakers application. Standard Ethernet communication protocols allow for fast system design, system control, and remote system monitoring. Analog and Dante® inputs are included in each model, for quick and easy integration into any new or existing system. Community-authored loudspeaker presets include equalization, high pass filters, and multi-stage limiters tailored to each model, ensuring consistent sound quality and full loudspeaker protection in every application.

### ALC Application Note

Total available power can be safely distributed asymmetrically across the outputs in any combination of low impedance and 70V/100V loads. Power delivered from each output is individually managed; total shared power per ALC is monitored and limited independently by the power supply.

### ALC-404D

- 4 inputs (Analog and/or Dante®)
- 4 channels of amplification and DSP processing
- Each channel provides up to 400W of power into low impedance or 70V/100V loads, stable to 2Ω
- In bridged mode, each pair of channels provides up to 800W into 8Ω, 4Ω, or 70V/100V loads
- Total shared power not to exceed 1200W
- Perfect for Small R SERIES, V SERIES, Compact I SERIES, W SERIES (W2), and ENT200 models, and zoned C SERIES & D SERIES applications

### ALC-1604D

- 4 inputs (Analog and/or Dante®)
- 4 channels of amplification and DSP processing
- Each channel provides up to 1600W of power into low impedance or 70V/100V loads, stable to 2Ω
- In bridged mode, each pair of channels provides up to 3200W into 4Ω, or 70V/100V loads
- Total shared power not to exceed 4800W
- Perfect match for Larger R SERIES & W SERIES, I SERIES, IV6 and ENT-FR

### ALC-3202D

- 2 inputs (Analog and/or Dante®)
- 2 channels of amplification and DSP processing
- Each channel provides up to 3200W of power into low impedance or 70V/100V loads
- In bridged mode, each pair of channels provides up to 6400W into 4Ω, or 70V/100V loads
- Total shared power not to exceed 6400W
- Perfect for R6-MAX, I SERIES Subwoofers and larger IV6 Arrays

| Models    | Power @ 2Ω | Power @ 4Ω | Power @ 8Ω | Bridged @ 4Ω | Bridged @ 8Ω | 70V       | 100V      | Max Output Voltage @ Lo-Z |
|-----------|------------|------------|------------|--------------|--------------|-----------|-----------|---------------------------|
| ALC-404D  | 4 x 400W   | 4 x 400W   | 4 x 400W   | 2 x 800W     | 2 x 800W     | 4 x 400W  | 4 x 400W  | 80 Vpk                    |
| ALC-1604D | 4 x 1600W  | 4 x 1400W  | 4 x 1250W  | 2 x 3200W    | 2 x 2800W    | 4 x 1600W | 4 x 1600W | 142 Vpk                   |
| ALC-3202D | 2 x 3200W  | 2 x 2400W  | 2 x 1250W  | 1 x 6400W    | 1 x 4800W    | 2 x 3200W | 2 x 3200W | 142 Vpk                   |

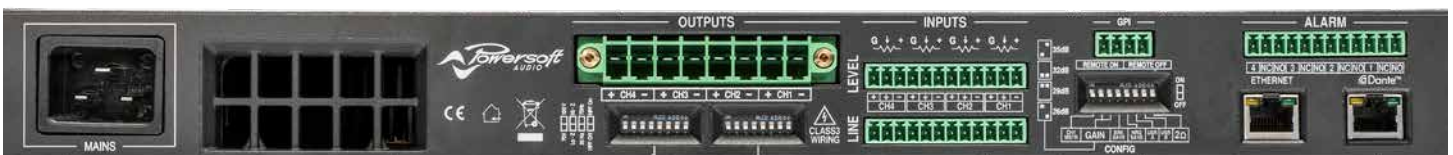

Rear Panel of ALC-404D and ALC-1604D

Visit [www.communitypro.com](http://www.communitypro.com) to learn more, or contact the Community TAG Team (Technical Applications Group) for technical and applications assistance at 1+ (610) 876-3400 or [tagteam@communitypro.com](mailto:tagteam@communitypro.com)

Dante® is a registered trademark of Audinate Pty Ltd.

# Loudspeaker Specifications

Please refer to the Community website for additional information and full specifications

## I SERIES

### Point Source 600 Medium Power 12" or 15" Two-Way Loudspeakers

Medium power 600W continuous power handling, 12-inch (305mm) ferrite woofer with 2.5-inch (64mm) voice coil, or 15-inch (381mm) ferrite woofer with 3-inch (76mm) voice coil, and 1.4-inch exit, 3-inch (76mm) voice coil titanium diaphragm ferrite HF driver. Rotatable constant-directivity horns. User selectable passive or biamp operation. Easily configured low profile rigging hardware available for multiple indoor applications (see BalancePoint™ Flyware information).

#### IP6-1122 12" two-way

- **Transducers:** LF 1 x 12", HF 1 x 1.4"
- **Operating Range / Sensitivity\*:** 37 Hz - 19 kHz; 94 dB
- **Beamwidth HxV:** 60° x 40°, 60° x 60°, 90° x 40°, 90° x 60°, 90° x 90°, 120° x 60°
- **Impedance:** 8 ohms

#### IP6-1152 15" two-way

- **Transducers:** LF 1 x 15", HF 1 x 1.4"
- **Operating Range / Sensitivity\*:** 30 Hz - 19.5 kHz; 95 dB
- **Beamwidth HxV:** 60° x 40°, 60° x 60°, 90° x 40°, 90° x 60°, 90° x 90°, 120° x 60°
- **Impedance:** 8 ohms

### Point Source 800 High Power 15" Three-Way Loudspeakers

High power, 600W (LF) / 275W (MF/HF) continuous power handling, 15-inch (381mm) neodymium woofer, 2-inch exit M200HP ketone polymer MF compression driver, 1.4-inch exit ketone polymer diaphragm neodymium HF driver. Rotatable constant-directivity horns. User selectable biamp or triamp operation. Easily configured low profile rigging hardware available for multiple indoor applications (see BalancePoint™ Flyware information).

#### IP8-1153 15" three-way

- **Transducers:** LF 1 x 15", MF 1 x 2", HF 1 x 1.4"
- **Operating Range / Sensitivity\*:** 33 Hz - 18.5 kHz; LF 96 dB, MF/HF 107 dB
- **Beamwidth HxV:** 60° x 40°, 60° x 60°, 90° x 40°
- **Power and Impedance:** 600W (LF), 275W (MF/HF) continuous @ 8 ohms

## Subwoofers

I SERIES similar-sized rectangular enclosures, construction, finish and aligned suspension points for seamless flown array integration. User selectable single amp or dual amp operation on the dual subwoofer models. Rubber feet included for floor installation. Easily configured low profile rigging hardware available for multiple indoor applications (see BalancePoint™ Flyware information).

### IS600 Family (Medium Power)

- **LF Transducers:** Single or Dual 12", 15", 18" - Ferrite
- **Power:** Single LF - 700W @ 8 ohms  
Dual LF - 1400W @ 4 ohms

### IS800 Family (High Power)

- **LF Transducers:** Single or Dual 12", 15", 18" - Neodymium
- **Power:** Single LF - 1000-1600W @ 8 ohms  
Dual LF - 2000-3200W @ 4 ohms

### Compact 600 Two-Way Loudspeakers

Designed to provide fill and distributed coverage for smaller spaces, they are styled and voiced similarly to the larger I SERIES models. The 6.5-inch IC6-1062 has 100° x 100° coverage. Both the single 8-inch IC6-1082 and dual 8-inch IC6-2082 have rotatable constant-directivity horns (HxV: 90° x 60° or 120° x 60°). All I SERIES Compacts are available in passive or 70V/100V models. U-Brackets and Vertical Yokes are mounting options.

#### IC6-1062

- **Operating Range:** 56 Hz - 18.5 kHz
- **Power and Impedance:** 150W continuous @ 8 ohms

#### IC6-1082

- **Operating Range:** 53 Hz - 19.5 kHz
- **Power and Impedance:** 250W continuous @ 8 ohms

### Modular Vertical Array 600

A scalable, adaptive sound reinforcement system featuring two full-range array elements with complementary, discreet vertical coverage angles (5°/15°) permit the creation of long throw line arrays, medium throw progressive curvature arrays and compact constant-curvature arrays. Up to 5° of splay between elements eliminates excessive overlap or coverage gaps.

Built-in Passive Acoustic Optimization (PAO) provides up to 19dB of frequency-selective attenuation within each element for unmatched SPL coverage consistency without additional amp or DSP channels. An exclusive PAO module within EASE® Focus 3 software quickly calculates ideal passive array parameters.

A matching, arrayable, high power 18" subwoofer provides low frequency support for any array configuration.

#### IV6-1122 12" two-way

- **Transducers:**  
LF 1 x 12", HF 2 x 1.7" voice coil
- **Operating Range / Sensitivity\*:**  
40 Hz - 18.5 kHz; 101 dB
- **Beamwidth HxV:**  
120° x 5°, 120° x 15°
- **Power:** 400W @ 16 ohms

#### IV6-1185

- **LF Transducer:** 1 x 18"
- **Power:** 800W @ 8 ohms

\*Highest representative output among various horn pattern options per model.  
dB SPL sensitivity is measured at 1W/1m  
Full specifications for these, and other models, are available at [www.communitypro.com](http://www.communitypro.com).

Loudspeaker data files are available for EASE and EASE Focus acoustic modeling software to facilitate optimum system design.  
(EASE® and EASE® Focus are products of AFMG Technologies GmbH.)

## E SERIES

### ENTASYS Two-Way Point Source Column, 6 LF Drivers (ENT206)

- **Transducers:** LF 6 x 80mm long excursion mylar, HF 2 x 3-element CRE
- **Operating Range / Sensitivity:** 120 Hz - 22 kHz, 93 dB SPL
- **Beamwidth HxV:** 140° x 20°
- **Power and Impedance:** 150W RMS, 375W PGM, 8 ohm or 70V/100V operation

### ENTASYS Two-Way Point Source Column, 12 LF Drivers (ENT212)

- **Transducers:** LF 12 x 80mm long excursion mylar, HF 4 x 3-element CRE
- **Operating Range / Sensitivity:** 100 Hz - 22 kHz, 96 dB SPL
- **Beamwidth HxV:** 140° x 15°
- **Power and Impedance:** 325W RMS, 800W PGM, 8 ohm or 70V/100V operation

## V SERIES

### Compact V2 Loudspeakers

Compact 11-ply birch enclosure, DYNA-TECH™ driver protection system, rotatable horn, steel yoke bracket included with vertical standoffs allowing 0°/10°/20° tilt, autoformer models available for 70V/100V applications.

- **Transducers:** LF single/dual 6.5" or 8", HF 1 x 1"
- **Operating Range\* / Sensitivity:** 60 Hz - 18 kHz; 92-94 dB
- **Beamwidth HxV:** 90° x 70°

### Two-Way 12" or 15" Full-Range

- **Transducers:** LF 1 x 12" or 1 x 15", HF 1 x 1"
- **Operating Range / Sensitivity:** 60 Hz - 18 kHz; 98-99 dB
- **Beamwidth HxV:** 60° x 40°, 90° x 60°
- **Power and Impedance:** 200W RMS, 500W PGM, 8 ohms

### Three-Way 12" Full-Range

- **Transducers:** LF 1 x 12", MF 1 x 6.5", HF 1 x 1"
- **Operating Range / Sensitivity:** 60 Hz - 18 kHz; 99-100 dB
- **Beamwidth HxV:** 60° x 40°, 90° x 40°
- **Power and Impedance:** 200W RMS, 500W PGM, 8 ohms

### ENTASYS Three-Way Full-Range Line Source Column (ENT-FR)

- **Transducers:** LF 6 x 3.5", MF 18 x 2.35", HF 42 x 1"
- **Operating Range:** 200 Hz - 20 kHz
- **Beamwidth HxV:** 120° x 12° (or user adjustable to 6° V)
- **Power and Impedance:** 1500W PGM, 12 ohms

### Three-Way 15" Full-Range

- **Transducers:** LF 1 x 15", MF 1 x 6.5", HF 1 x 1"
- **Operating Range / Sensitivity:** 55 Hz - 18 kHz, 99-100 dB
- **Beamwidth HxV:** 60° x 40°, 90° x 40°
- **Power and Impedance:** 200W RMS, 500W PGM, 8 ohms

### Subwoofers

#### VLF208LV: compact low profile

- **Transducers:** LF 2 x 8" large volume
- **Operating Range / Sensitivity:** 30 Hz - 1000 Hz
- **Power and Impedance:** 400W continuous, 4 ohms

#### V2-212S:

- **Transducers:** LF 2 x 12"
- **Operating Range / Sensitivity:** 35 Hz - 200 Hz, 97 dB SPL
- **Power and Impedance:** 300W continuous, 4 ohms



*Community Professional Loudspeakers is a developer and manufacturer of innovative loudspeaker systems for installed sound applications.*

*Community products elevate the listening experience at the world's foremost indoor and outdoor sports venues, auditoria, theme parks, worship facilities and convention centers.*

*For applications that demand reliable, long-term performance and consistent, high-quality sound – often in extreme and challenging environments – Community loudspeakers provide the critical listening experience audiences deserve and facility managers demand.*

*Based in Chester, Pennsylvania, Community is an American original whose innovative products have shaped the professional sound industry since the company was founded in 1968.*

**Community Professional Loudspeakers**

333 East Fifth Street, Chester, PA 19013-4511 USA

Phone: +1 610 876 3400 • Fax: +1 610 874 0190

**communitypro.com**